



Companion Bike Seat Installation Guide

This manual describes how to install your Companion Bike Seat starting from a bicycle with a solid rear axle. If you have a quick-release hub, you will need to swap this out with a solid axle before you can install your Companion Bike Seat. If you are installing a new solid rear axle on your bicycle, we recommend you purchase the sturdiest version possible for the particular make and model, as this will maximize longevity of your bicycle and your bike seat.

If you are unsure on how to install a new rear axle on your bicycle, we recommend you consult with your local bike shop to make sure you purchase the right part and install it properly.

Contents:

- Installing Foot Pegs
- Installing Seat-Post Clamp
- Installing your Companion Bike Seat
- Adjusting your Companion Bike Seat
- Opening and Closing the Stash-box (optional)

Installing Foot Pegs:

1. Remove axle nuts holding rear wheel.

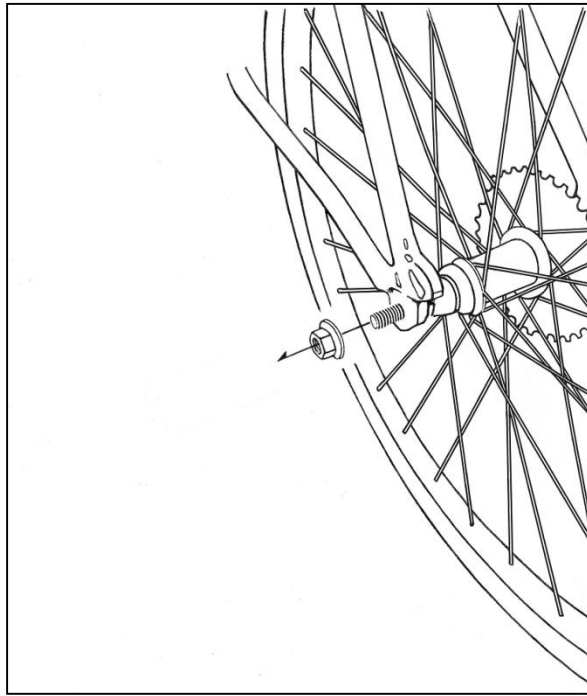

2. Fit foot pegs over axle thread. Thread axle nuts onto rear axle inside each foot peg.

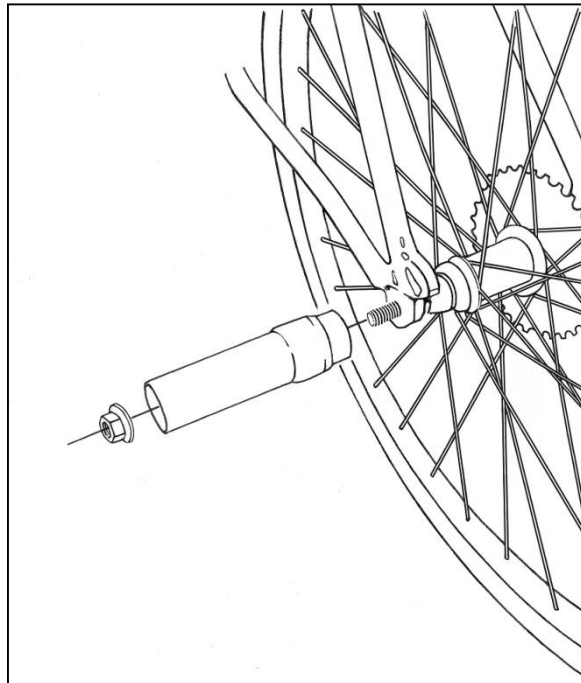

Installing Seat-Post Clamp:

1. Remove seat and seat-post from bicycle.

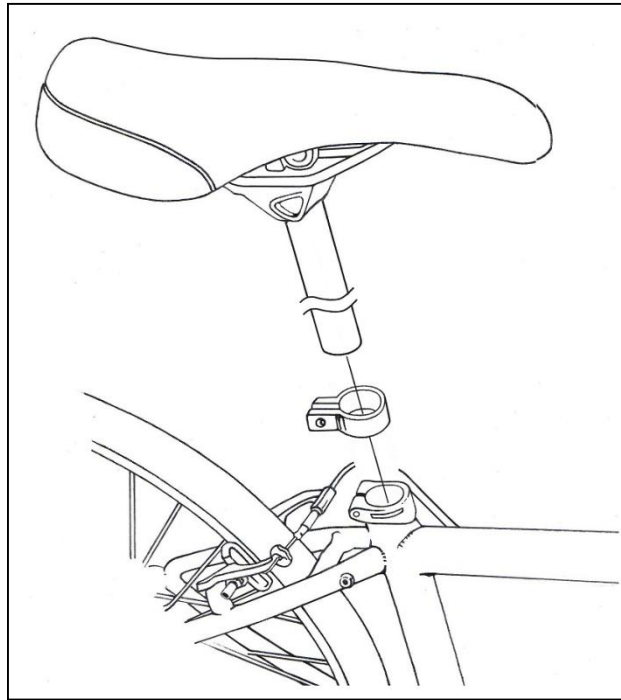

2. Slide the Companion Bike Seat seat-post clamp onto the seat post and re-install the bicycle seat and seat-post.

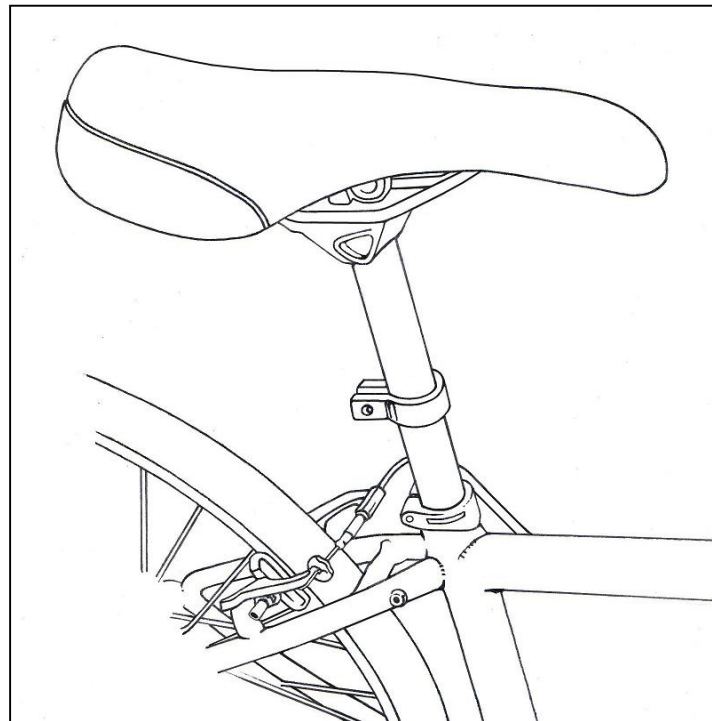

Installing your Companion Bike Seat:

1. Remove foot peg clamps from the Companion Bike Seat.

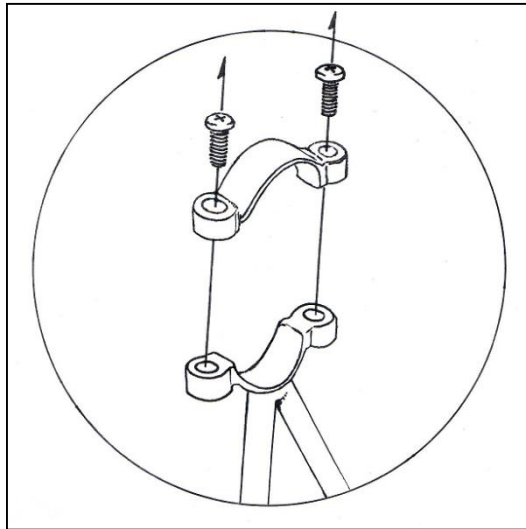

2. Position the Companion Bike Seat frame so that its resting on the foot pegs with the turnbuckle facing the seat of the bicycle.

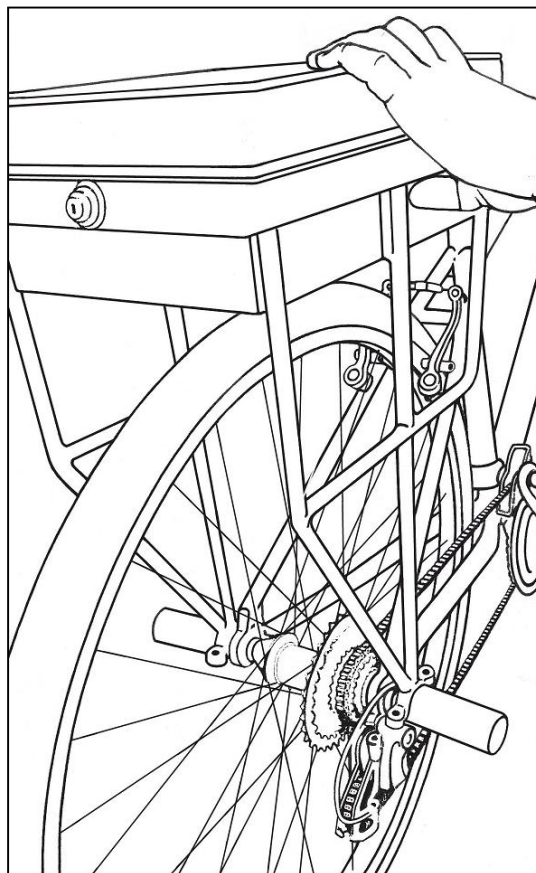

3. Attach one end of the turnbuckle to the front of the Companion Bike Seat frame. There are two eyelets on the front of the Companion Bike Seat frame to attach the turnbuckle to.

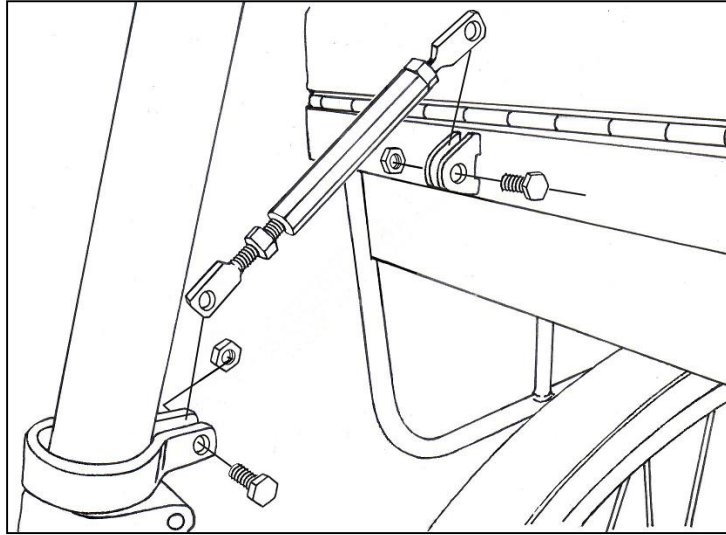

Attach the loose end of the turnbuckle to the Companion Bike Seat seat-post-clamp and tighten.

4. Attach both foot peg clamps using the included screws.

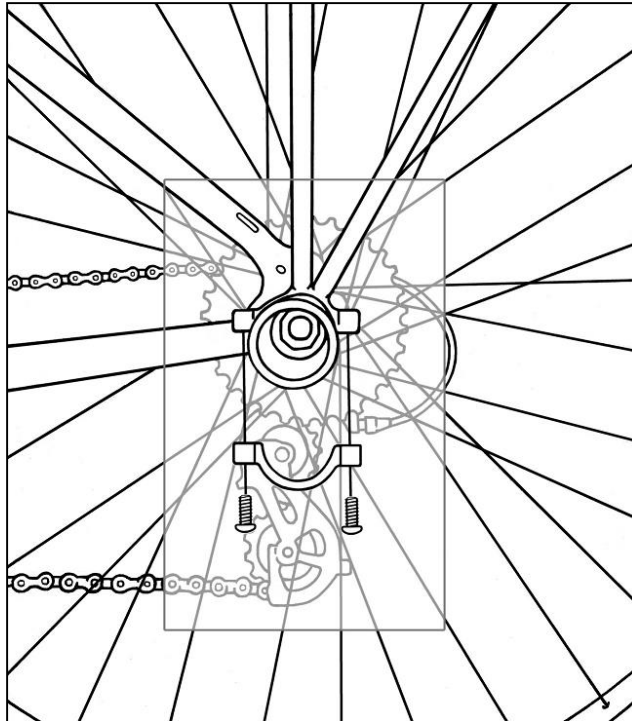

You're almost done!

Adjusting your Companion Bike Seat:

1. Spin the turnbuckle to tighten or loosen until the Companion seat cushion is parallel to the ground.

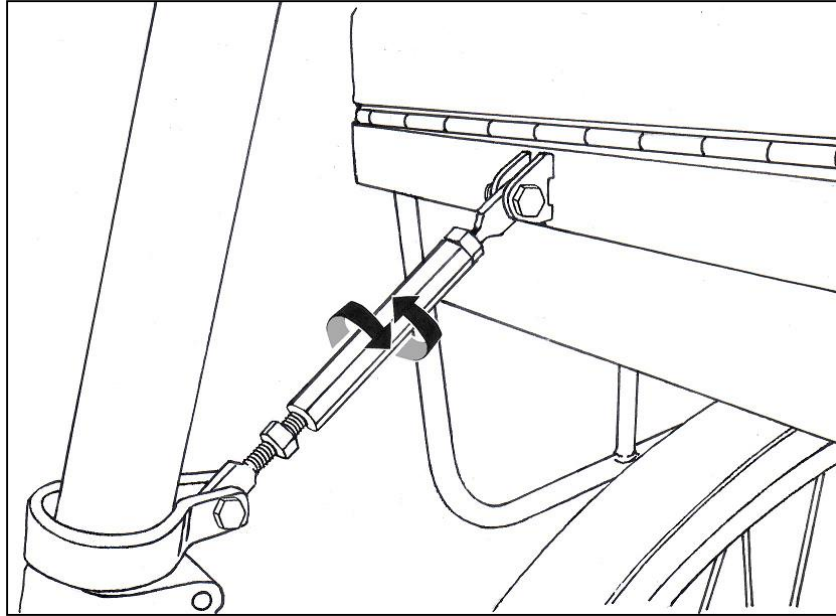

2. Tighten nuts on both sides of the turnbuckle to lock the turnbuckle in place.

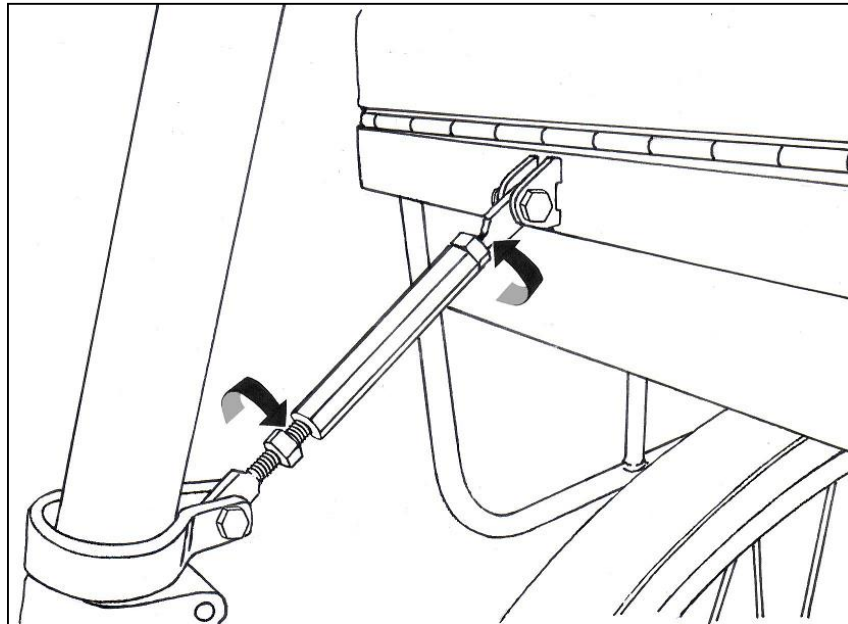

Opening and Closing the Stash-box:

1. Insert the key into the lock.

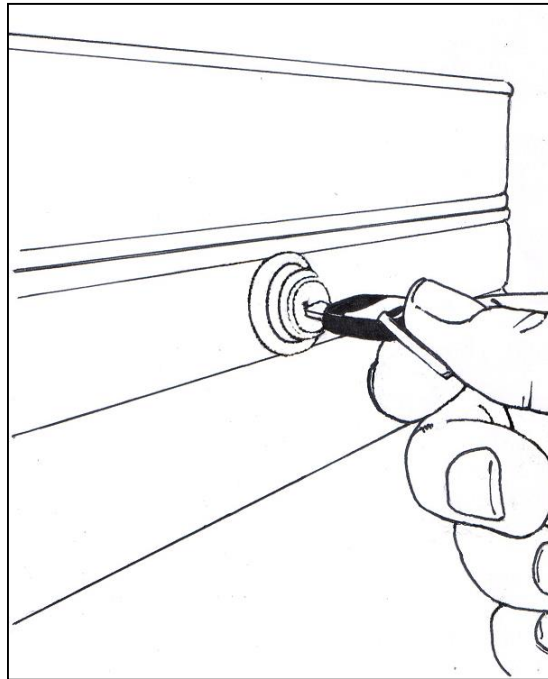

2. Twist to release the lock until the button pops out. The stash-box is now unlocked and can be opened.
3. Simply depress the button in order to lock the stash-box again.

NOTICE

Not Intended for Children 12 and Under

Your Companion Bike Seat has been designed for general transportation and recreational use, but has not been designed to withstand abuse associated with mountain biking, stunting, jumping or off-road use.

Companion Bike Seats are intended to be ridden on paved roads only. The bicycle should not be taken off-road while there is a passenger on the Companion Bike Seat.

Companion Bike Seat is designed to allow for one passenger to ride (in addition to the rider) on a bicycle. It is not designed to safely allow multiple passengers to ride on the Companion Bike Seat.

It is the responsibility of the individual consumer purchaser to assure that all parts included are properly installed, all functional parts are adjusted properly, and subsequent normal maintenance services and adjustments necessary to ensure safe operation are properly made.

For more detailed warranty information, please visit our website at www.thebikeseat.com/warranty.html.

COMPANION BIKE SEAT, LLC WILL NOT BE LIABLE FOR ANY LOSS OR DAMAGE, INCLUDING ACCIDENTAL, INCIDENTAL OR CONSEQUENTIAL DAMAGES OF ANY KIND, WHETHER BASED ON CONTRACT, WARRANTY, NEGLIGENCE, PRODUCT LIABILITY, OR ANY OTHER THEORY, AND ARISING IN CONNECTION WITH THE SALE, USE, MISUSE, OR REPAIR OF THIS PRODUCT.

REMEMBER, ALWAYS WEAR A HELMET!

